

Geomagnetism Canceller/Simulator

PALMGAUSS-S

By combining Helmholtz Coils in a 3-axis configuration, it is possible to create magnetic fields in a space in the center. Ideal for the calibration and evaluation of geomagnetic sensors.

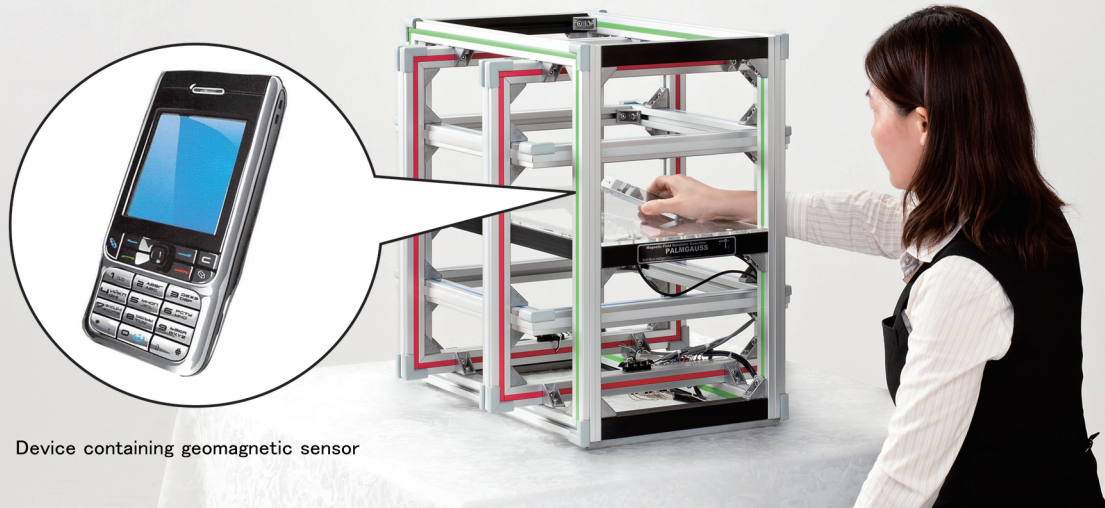

Application 1: Calibration and evaluation of geomagnetic sensors or e-compasses

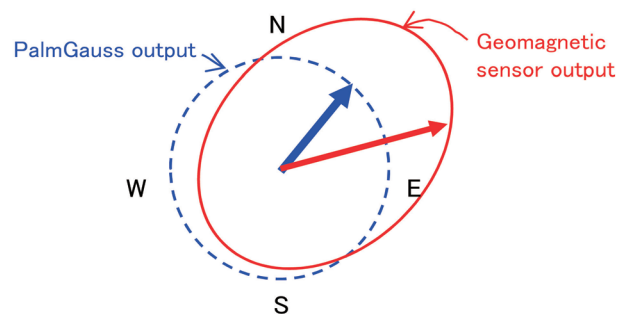
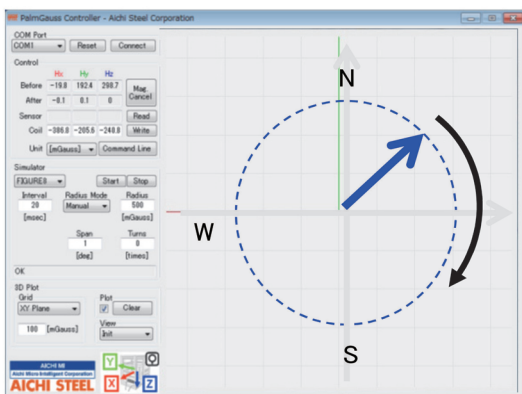

Use case) Evaluation of azimuth accuracy
Create a circular field and evaluate azimuth accuracy from the geomagnetic sensor output

Application 2: Replicate magnetic environments

Geomagnetic data (Sample)

Xaxis	Yaxis	Zaxis
0mG	0mG	0mG
300mG	0mG	0mG
285mG	0mG	95mG
150mG	70mG	250mG
100mG	250mG	-133mG

Use case) – Replicate the magnetic field of a calibration motion
– Compare and evaluate various conditions

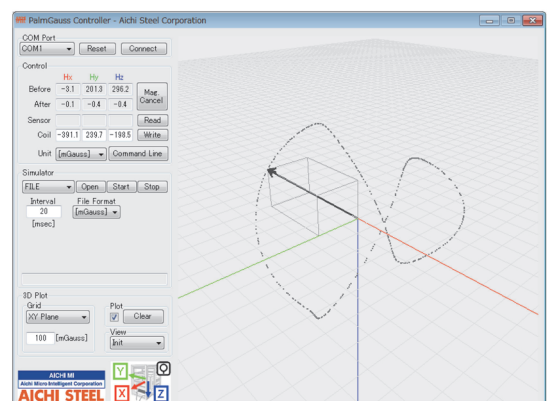

Principle of field generation

By arranging 3 sets of Helmholtz Coils orthogonally to each other, magnetic fields of any strength and in any direction can be created.

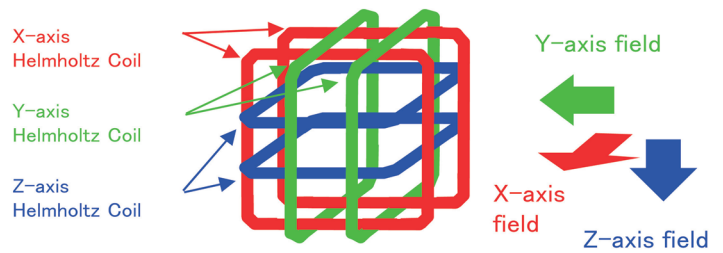

Block Diagram

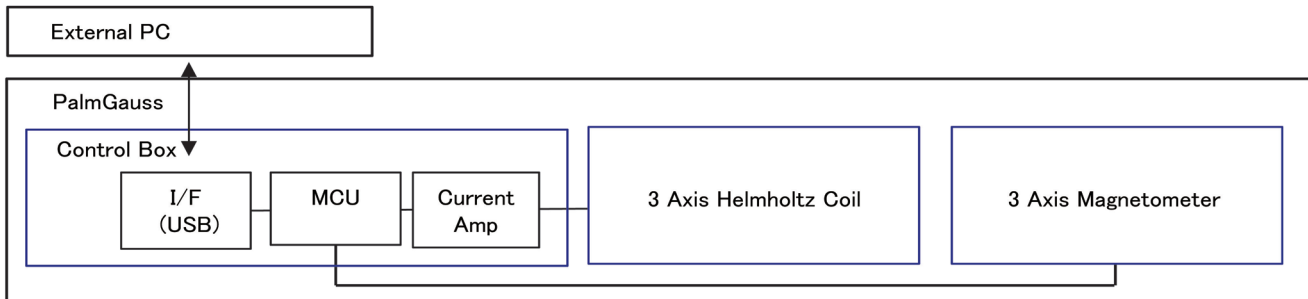

Basic Specification

Item	Model : PGS-5G	
Power Supply Voltage	AC90 to 240V (50 / 60 Hz)	
Power Consumption	< 400(V·A)	
Directions of Field Control	3 Axes (X,Y,Z)	
Controlled Area	$\pm 70 \times \pm 70 \times \pm 70$ mm	
Maximum Magnetic Field Strength	5.0 Gauss	
Magnetometer	Amorphous MI Measurement Range: ± 3 Gauss* Measurement Frequency: DC	
Field Strength in Cancelled Area	< 10mGauss (typical)	
Helmholtz Coils	X-axis	481 × 481 × 265 mm
	Y-axis	542 × 542 × 299 mm
	Z-axis	420 × 420 × 230 mm
Weight	Coil	21.5 kg
	Control Box	6.0 kg

※The attached sensor has a measurement range of ± 3 Gauss.

If a field exceeding ± 3 Gauss is applied, the sensor values will not be guaranteed.

Opening Dimensions (Supports not shown)

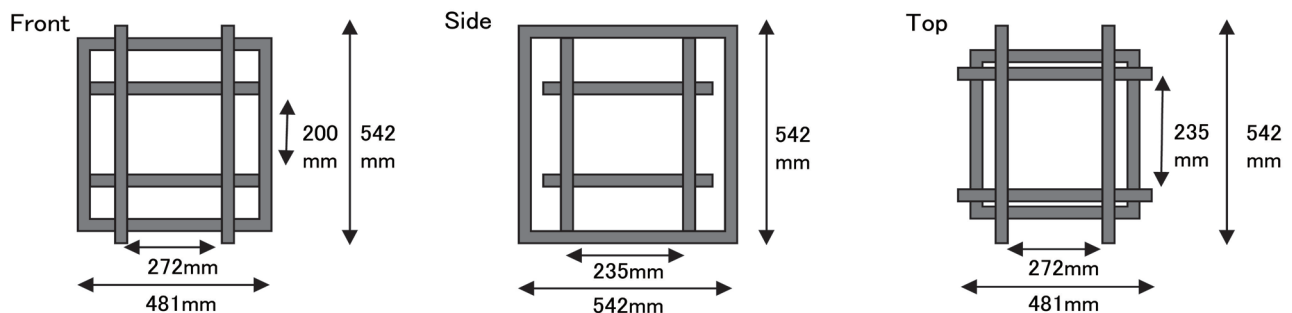

S/W Specification

Communication Specifications

1	Baud Rate	38400
2	Data Bit	8
3	Parity	None
4	Stop bit	1
5	Flow	None
6	Receive	LF
7	Transmit	CR+LF

Command Specifications (Extracts)

Parameter1	Parameter2	Comment
HELP		
HELP	MAG	
INFO		
V		
INIT	9600 or 38400	BR: Default 38400
MAG	CANCEL	

Sales

Aichi Steel Corporation

<http://www.aichi-steel.co.jp/>

1 Wano-wari, Arao-machi, Tokai-shi, Aichi-ken
476-8666 Japan
TEL: 052-603-9948